



Sales price £209.95

Sales price without tax £174.96
Tax amount £34.99

7el OWL Ultra - 144-145MHz for super low noise Yagi for weak signal operation



Description

A 7 element OWL-Ultra (3.1m long) Super low noise, light weight Yagi 144-145MHz Optimised for weak signal (EME) operation - New 2020 Model!

X-pol available upon request & full EME system prices available upon request - This email address is being protected from spambots. You need JavaScript enabled to view it.

FINALISED USING ANSYS HFSS fully meshed 3D Solver

Modelled and finalised with Ansys HFSS 2020 R2 fully meshed antenna modelling software. All aspects of the antenna are measured and modelled including boom, insulators and coax cable. This software is extremely accurate and once built, analyser plots match the simulation exactly. However, the investment required runs into £10,000's in annual lease costs and thus, this investment is reflected in the antenna pricing [ANSYS](#).



4 x 7el OWL Ultra @ FG8OJ who says this below:

"Hi Justin,

Just few words about your antennas :

I already know that your are doing amazing antennas because my 6m 7 elements LFA let me lot of huge qsos, this year : 12 006 km with EY8MM, 10 896 km with 9K2GS.

About the 4 x 7el OWL-Ultra Super low noise Yagi, in 5 days of EME activity : 55 initials EME qso's 47 unique 4 characters grids and 21 DXCC
[undefined](#)

73, Burt FG80J"



"Hi Justin

Finally I put up my antennas so I send you a photo for your archives.

SWR is below 1.2:1 and even beaming 150° I was 59 in Santa Maria Island (135°), 260 Km apart.

The rotor is not ready yet so no azimuth nor elevation.

But first impression in great. Thanks a lot.

73 de CU3AA, Joao"



A pair of 7el OWL Ultra's being installed at ON4EC

A note on accuracy

In order for a low noise VHF or UHF Yagi modelled in software to stay low noise when built, the whole antenna needs to be modelled, optimised and finalised as it will be built. Elements, boom, insulators, feedpoint and even coax cable being connected to the model. This way no 'correction' needs to be added, the exact element lengths are given within the software which in our case is the World's leader and most expensive simulation package available today Ansys HFSS.

a 'Fixed' length correction such as formulas given by K1FO and DL6WU, will NOT replicate a wires only model to real world antenna. Any such correction would be percentage based with a lower percentage being needed for first and last elements.

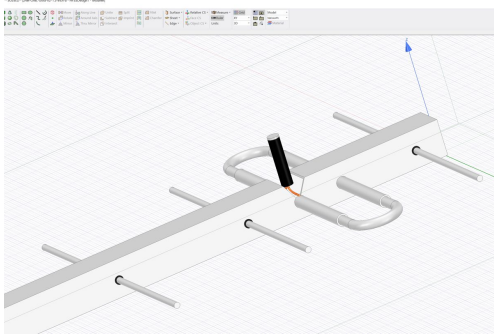

A 70cms LFA Yagi as presented within Ansys HFSS showing all aspects of the antenna being factored into the model

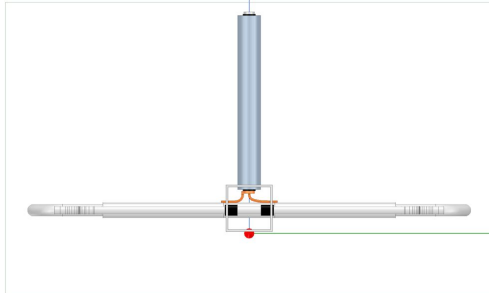

A 70cms Ultra Yagi from the front in Ansys HFSS with ferrite core balun attached. All aspects of the antenna are factored into the design

A 7el 144MHz OWL Ultra installed and ready for action

Fully customisable design - what you want, we will make

If you require a **larger diameter boom**, rear mount, **X-pol**, a variation in frequency coverage or other variation, contact This email address is being protected from spambots. You need JavaScript enabled to view it. detailing your requirement for a custom quote.

The very latest G0KSC designs

The G0KSC OWL Ultra is another fantastic design by G0KSC. A low impedance Yagi provides excellent performance. However, traditionally, low impedance has meant narrow bandwidth.

G0KSC developed the OWL (**O**ptimised **W**ideband **L**ow impedance Yagi) with a folded dipole driven element which this has increased the feed point from 12.5 Ω impedance to 50 Ω . This along with careful, long duration computer optimisation has resulted in a much wider bandwidth than previously seen in native low impedance Yagis.

THE Low Noise Yagi dubbed the 'Urban Yagi'

The super low noise characteristics of the OWL Ultra mean you can HEAR as well as be heard in today's modern and very noisy city environments. If you want the very best option for minimal noise pick-up in Urban and city locations, the OWL Ultra is for you.

Best in Class performance in terms of G/T?

Antennas finalised in fully 3Dmeshed packages with thru-boom elements are not easily reverse engineered into EZNEC and the VE7BQH table required NEC based models in order to be listed.

Excellent wet weather performance

The OWL Ultra is usable in all weathers. Unlike some antennas that shift frequency and become unusable when wet, the OWL Ultra remains perfectly usable.

Latest and best G0KSC designs only available through InnovAntennas

The OWL-Ultra is the latest, 3rd generation OWL and provides G/T performance not seen at this boom length previously (VE7BQH independent comparison list). **The latest G0KSC designs are ONLY available through InnovAntennas.**

Elevation lobe suppression is key

One of the reasons the OWL Ultra performance is better than other Yagis of the same size is the special attention paid to elevation lobes during the optimisation process. Whether you believe you live in a quiet location or not, elevation lobes will ensure your received noise floor is higher

than it would otherwise be if they were greatly suppressed. Even if you have a shack in the middle of open countryside, if your shack is directly below the antenna or in view of the antenna in certain directions, noise from everything in the shack (from computers, modems, LED lamps, alarms WiFi adapters etc.) will increase your noise floor. The highly suppressed elevation lobes of the OWL Ultra will ensure your noise floor is as low as possible.

All elements and dipole perfectly in-line

All of the thru-boom OWL and LFA Yagis, all elements, including the feed point are perfectly in-line and as there are no 'lossy' matching devices standing off of the driven element to distort pattern pattern remains perfectly clean and this means the low noise properties of the antenna remain.

Grounded driven element

There are many associated benefits of having the driven element electrically connected to the boom and therefore grounded. This is much more difficult to achieve in a split dipole Yagi and in addition, not possible to model within NEC based simulation tools. The folded dipole or LFA loop is grounded to the boom opposite the feed point. This is a point of zero current (everything radiated by this point) and therefore, is not seen at the design frequency. However, the dipole will become very high impedance either side of the design frequency very quickly and this, a Band Pass Filter property is added to the antenna 'for free'. Another associated benefit is having the driven element grounded means static cannot build up in the folded dipole as it could with a non-grounded driven element system and potentially damage the receiver as with the grounded system, static can drain harmlessly away

Mechanical design

The new OWL Ultra is designed in a light weight and very strong package with this particular model using a **3/4" square boom** with through boom (insulated) **1/4" solid rod elements**. The driven loop is adjustable in order to ensure absolute minimum return loss figures can be seen and is made from **1/2" tube with 3/8" diameter loop ends** which trombone to provide the finalisation tuning ability. The folded dipole is through the boom as are the parasitic elements although the section of loop opposite the feed point is grounded to help reduce noise and to help protect the receiver front-end against static. Grounding the loop in this way also provides a band pass filter characteristic. The feed impedance goes very high quickly once moving away from the 2m ham band and this results in a filter property being added to the antenna for out-of-band signals, received or transmitted.

G0KSC variable element correction applied - verified with Ansys HFSS

SWR characteristics are unparalleled as a result of the applying of G0KSC variable, percentage based correction to all through boom elements. Fixed length element correction does not match software models precisely. The correct method is to apply a % to the elements which vary greatly between the first (reflector) and last (final director) elements. However, an added complication is that the first and last few elements at either end of the boom, require less correction than those centrally mounted on the boom. HFSS Ansys allows for the modelling of the boom, insulators having the driven element electrically connected to the boom and much more in order there are no surprises or changes in pattern/performance or results once the antenna is built and installed.

Other benefits include:

- Marine grade stainless steel fittings
- Super-light but rigid construction
- Mill finished boom and elements for highest levels of accuracy
- Unparalleled after-sales support and assistance when needed

For more information [Email Here](#)

Performance

Gain: 13.15dBi @ 144.3MHz

F/B: 24.3dB @ 144.3MHz

Peak Gain: 12.89dBi

Gain 10m above ground: 18.71dBi

Peak F/B: 36.1dB

Power Rating: 5kw

SWR: Below 1.2:1 from 143.8MHz to 145.2MHz

Boom Length: 3.1m

7el OWL Ultra 144MHz EME Yagi & Weak signal

Weight: 1.7kg/3.7lbs

Safe Wind Speed: 160Kph/100Mph+

Turning Radius: 1.763m/3.88ft

Vertical Stacking: Between 1.8m and 2.4m for minimum under-lobes

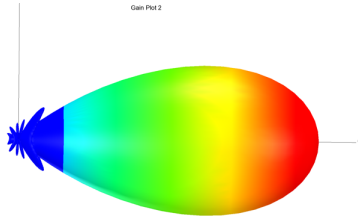

Elevation Plot of the 9el OWL Ultra presented within Ansys HFSS

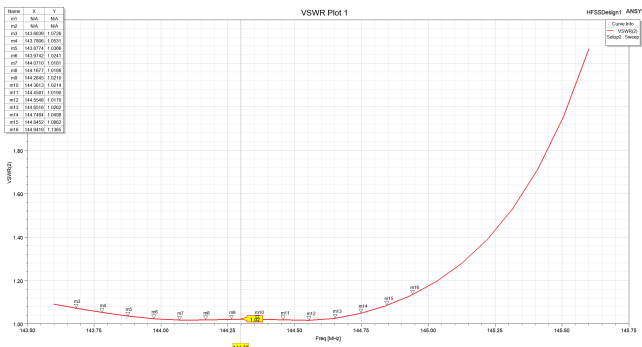

SWR Plot of the 9el OWL as presented in Ansys HFSS

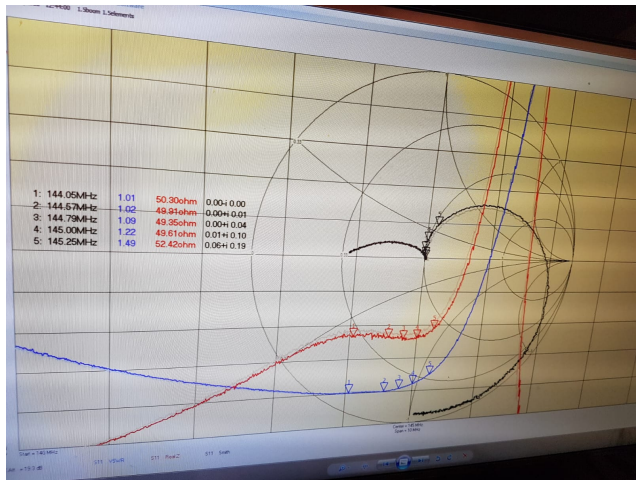

Measured SWR on a built 9el OWL Ultra by G8FJG

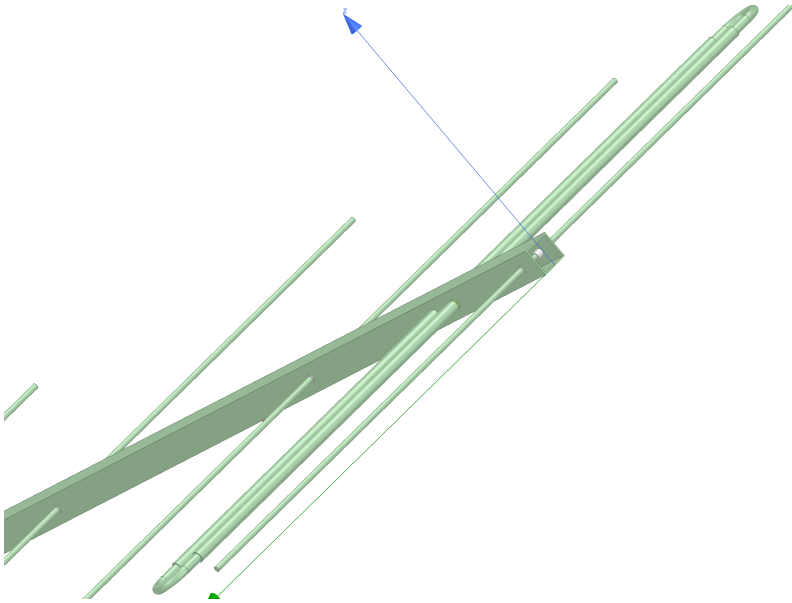

The fully 3D model as presented in Ansys HFSS - all factors of the antenna are represented in the model from the boom with insulated elements passing through it, insulators set in the boom and grounded driven loop. NO correction needs to be added to any of the elements, the antenna element sizes are finalised in the model and the built antenna represents the model perfectly.

//